

**COURSEMASTER**

---

**AUTOPILOTS**

Australia's world leader in autopilot technology

**CM800*i* & CM850*i*  
SYSTEM MANUAL**

12-04

# CM800*i* SYSTEM MANUAL

Your Coursemaster CM800*i* autopilot system is engineered for accurate and reliable steering. But remember that it cannot keep a lookout.

**SAFE NAVIGATION IS ALWAYS YOUR  
RESPONSIBILITY.**

COURSEMASTER AUTOPILOTS PTY LTD.  
2/66 GIBBES STREET,  
CHATSWOOD NSW. AUSTRALIA 2067  
ABN 25 001 306 369

Phone +612 9417 7097

Fax +612 9417 7557

E-mail: [sales@coursemaster.com](mailto:sales@coursemaster.com)

Website: [www.coursemaster.com](http://www.coursemaster.com)

## **THE CM800*i* SYSTEM**

The 'intelligent' CM800 autopilot system, with automatic tuning, may use CM800*i* or CM850*i* controllers in combination with a CM840 or CM841 Junction Box. This manual describes the use of each configuration and some details may therefore not apply to your particular system. It is possible also to upgrade an earlier CM800 system to the automatic tuning version simply by fitting a new software chip. Apart from the labels on the Control Heads, such a system will operate as described in this manual.

Suitable software is Version 2.04 or higher.

Copyright 2004. This manual, the mechanical and electronic design of the CM800 autopilot system and its associated software are protected by copyright. Unauthorised copying may result in prosecution.

## QUICK START

- Install and check the system as described in Chapter 3.
- Press the STANDBY key to turn the system on.
- Follow the on-screen instructions to carry out the initial setup
- Press the STANDBY and PILOT keys together to turn off.
- Steer to the desired course and press PILOT.
- Use the course knob and/or arrow keys to change or trim the course.
- To steer a course set by a GPS system, press NAV.
- Use the MODE key for access to alternate displays. Hold the MODE key for 2 seconds to display the menu options.
- Hold the PILOT key down for two seconds to activate the DODGE function. Use the arrow keys to dodge.
- Hold the PILOT key down for three seconds to activate the autotack function.

# CM800i SYSTEM MANUAL

## CONTENTS

<b>1. SYSTEM DESCRIPTION</b>	
1.1 Introduction to autopilots	1-1
1.1.1 The Reference Course	1-2
1.1.2 Steering Control	1-2
1.1.3 Power Steering	1-4
1.1.4 Options	1-4
1.1.5 Working with other Equipment	1-5
1.2 The CM800i System	1-6
1.3 Optional attachments	1-8
<b>2. OPERATING INSTRUCTIONS</b>	
2.1 The Control Panel	2-1
2.2 Getting Started	2-2
2.2 Normal Operation	2-5
Switching on	
Switching off	
Adjusting the course	
Dodge	
Autotack	
Auto Navigation	
Remote steering	
Wind Vane steering	
2.4 The Mode key	2-9
Sea state	
Rudder factor	
Navigation display	
2.5 Program Menus	2-11
2.6 Alarms	2-17
2.7 Recommended Settings	2-18

## CONTENTS

<b>3. INSTALLATION</b>	
Step-by-step Summary	3-1
3.1 Junction Box	3-2
3.2 Controller	3-4
3.3 Compass options	3-5
3.4 Rudder Transducer	3-7
3.5 Attachments	3-8
3.5.1 Remote Steering	3-8
3.5.2 Rate Gyro	3-9
3.5.3 Second Controller	3-9
3.5.4 Rudder Angle Indicator	3-10
3.5.5 Remote Alarm	3-10
3.5.6 NMEA Interfaces	3-10
3.6 Steering Drive	3-11
3.6.1 Chain driven mechanical	3-12
3.6.2 Solenoid-controlled hydraulics	3-14
3.6.3 Hydraulic System with Reversing Pump	3-14
3.6.4 Hydraulic linear drive	3-18
<b>4. TROUBLE-SHOOTING</b>	
4.1 General	4-1
4.2 Error messages	4-1
4.3 Other faults	4-3
4.4 Fuses	4-4
<b>5. SYSTEM SPECIFICATIONS</b>	5-1
<b>6. MAINTENANCE AND WARRANTY</b>	6-1

# CHAPTER 1 SYSTEM DESCRIPTION

## 1.1 INTRODUCTION TO AUTOPILOTS

The main function of a marine autopilot is to hold the heading of a vessel on a reference course which is held in the memory of the autopilot. When it is operating, the autopilot continuously compares the vessel's heading with a reference course, and if they are different, it applies helm to bring the vessel back on course. Since there has to be a compromise between the accuracy of course holding and the activity of the rudder, the autopilot has controls which let the user set the balance between these two factors.

The four basic components of an autopilot are a compass, an electronic control box, a rudder angle sensor (transducer) and the steering drive. See Fig 1.1. In a CM800i system, the electronics are housed in two cases - a Junction Box containing most of the system and a Controller (Control Head), which is mounted near the steering station.

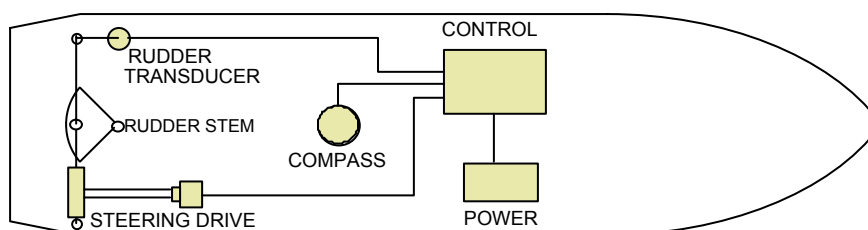

Figure 1.1 Basic components of a marine autopilot.

Modern autopilots perform other functions as well and this introduction explains how these fit in with the basic function and how they provide a wider range of options for the user.

### 1.1.1 THE REFERENCE COURSE

When the autopilot is first turned on, it rests in an idle (STANDBY) state in which it displays the heading, but does not steer the vessel. It is activated by switching it into the PILOT state. At the moment this is done, the current heading is put into memory as the reference course and the autopilot starts steering to hold the heading on this reference course. The user can change the reference course at any time and the heading will swing round to match the new course.

There are two other ways of setting the reference course. If the autopilot is connected to a GPS navigation receiver, the heading is then controlled to place the vessel on a direct track between the origin waypoint and the next waypoint. The third option may be used on yachts fitted with a compatible wind instrument. In this case, the reference course adjusts itself to maintain a constant apparent angle to the wind.

### **1.1.2 STEERING CONTROL**

When the vessel swings off course or the reference course is changed, the autopilot should apply helm in a way which brings the vessel onto course quickly, but without overshooting the reference course. The correct rudder angle depends on the amount of the error, the speed of the vessel, its size and the effectiveness of its rudder.

#### **Automatic Tuning**

In an auto-tuning autopilot, such as the CM800i system, this choice of the appropriate rudder correction is made automatically. The autopilot uses data about the type of vessel, which is entered during the set-up operation. Then, as the vessel travels, the autopilot continuously monitors the accuracy of course holding and the level of rudder activity. It then chooses internal settings which achieve the best compromise between these two measures of performance. There is also an option to operate in a manual tuning mode, in which case, the following comments apply.

#### **Rudder Factor (Manual)**

The sensitivity or RUDDER FACTOR sets how many degrees of helm are applied for a given course error. A mid-range rudder factor setting applies half a degree of helm for each degree off course. In large or slow vessels it would be more and in light, fast boats it may be less.

Setting the rudder factor too high causes oversteering or 'snaking' as illustrated in Fig 1.2. Too low a setting causes understeer and a sluggish response. Fortunately, most vessels tolerate a range of settings and still steer well.

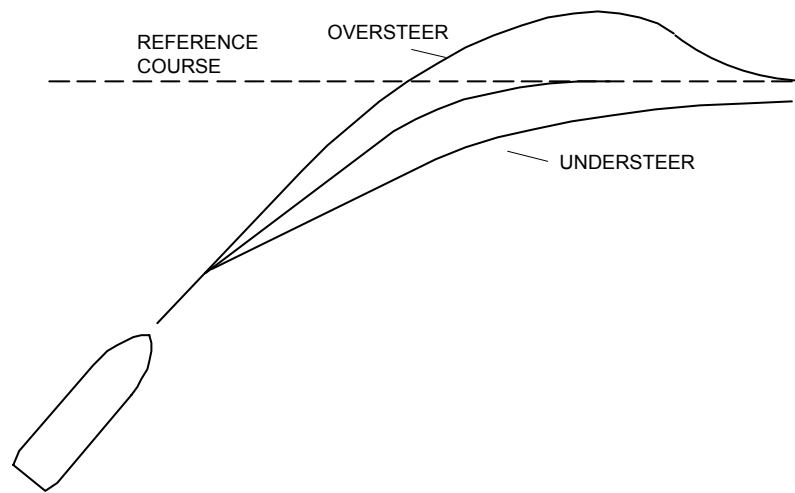

Figure 1.2. Illustration of oversteer if the rudder factor is set too high and understeer if it is set too low.

### **Sea State (Manual)**

The SEA STATE setting is influenced by the sea conditions and the weight of the vessel. The NORMAL applies helm in proportion to the course error and the rate of turn. The ROUGH mode is used when the vessel rolls and yaws in a heavy sea. Rudder activity is quietened down by not reacting to small heading shifts, but full control is applied as the shift becomes larger. The rate of turn component in the helm correction is adjustable and is important for vessels whose helm response is slow and/or continue to turn for some time after helm is removed. When there is a turn-rate (or counter rudder) component, normal helm is applied to start the vessel turning. As the turn rate builds up, the helm is backed off. When the vessel is close to the reference course, reverse helm or counter-rudder is applied to stop the turn.

The action of the rate or counter-rudder during a turn is illustrated in Fig 1.3. Generally, when the rate component is increased, vessels hold a course better but react to changes in the reference course more slowly. Counter-rudder also improves control for most vessels operating in a following sea.

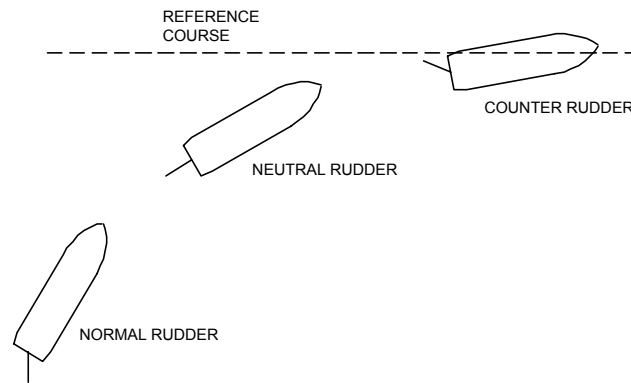

Figure 1.3 Rudder action during a turn in the RATE mode.

### **Autotrim**

Vessels often show a steering bias or offset, which can be due to weather, propeller torque or towing a load off-centre. The autopilot responds to this by progressively trimming the centre position of the rudder until the average heading of the vessel equals the reference course.

#### **1.1.3 POWER STEERING**

Since the autopilot controls a power steering system, options are available to use this to steer the vessel by hand while away from the main wheel. This can be done by a hand-held device on a cable or a permanently mounted second steering station.

#### **1.1.4 OPTIONS**

An autopilot commonly uses a fluxgate compass for its heading measurement. Such compasses, though effective, suffer from acceleration errors and a very effective way to reduce these errors is to combine a fluxgate with a rate-of-turn gyro. A further option is to fit a pickup device (slave) on the ship's compass and take advantage of its dynamic performance and the fact that it has been magnetically compensated. Alternatively, this autopilot may take its heading in digital form from a ship's gyro or

other electronic heading sensor. The autopilot has built-in facilities for automatic or manual compass calibration.

When connected into an NMEA data system, the autopilot can receive navigation data, as mentioned above or wind direction data. Some of this data, which is not used for autopilot operation, is displayed on the autopilot screen for convenience. The autopilot generates output data containing the current heading, which can be fed into an instrument or radar system.

Autopilots intended for yacht use have an automatic tacking feature which is useful for single-handed sailing.

A second control head may be fitted to the autopilot to provide parallel operation from two stations.

### **1.1.5 WORKING WITH OTHER EQUIPMENT**

The physical and electrical environment in a boat can be harsh. This autopilot has been engineered with this in mind and tolerates poorly regulated power supplies, overloaded steering, radio transmitters, radars and the like. Conversely, it has also been engineered to operate without causing interference to radio receivers and other communications equipment. Coursemaster autopilots carry a CE mark to indicate compliance with the relevant EMC standards. The installation sections of this manual have been carefully developed to minimise problems when the autopilot is in this environment. Please study and follow them!

## **1.2 THE CM800i SYSTEM**

The core of the CM800i system is built by connecting a Controller to a Junction Box. There is a choice between two versions of the Controller and two versions of the Junction Box. A comparison of their features between is shown in Fig 1.4 below.

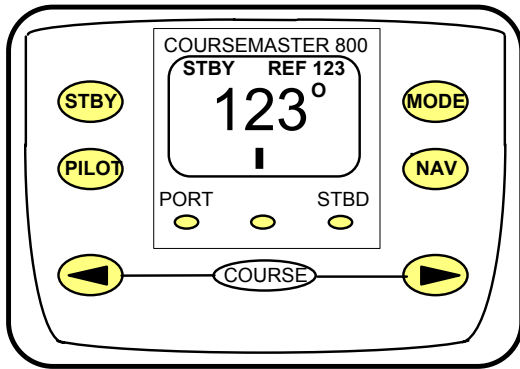

CM800i Controller

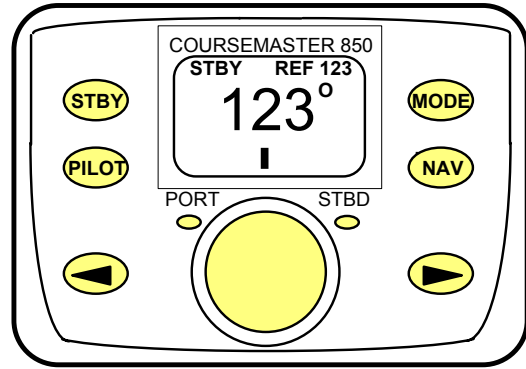

CM850i

- |   |  |
|---|--|
| <ul style="list-style-type: none"> <li>• Three course indicators</li> <li>• Keys for course adjustment</li> </ul> | <ul style="list-style-type: none"> <li>• Two course indicators</li> <li>• Knob and keys for course adjustment</li> </ul> |
|---|--|

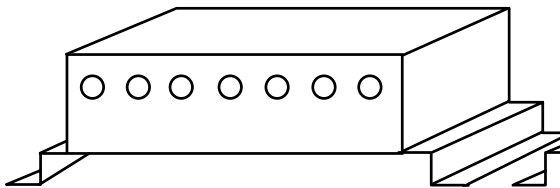

CM840 Junction Box

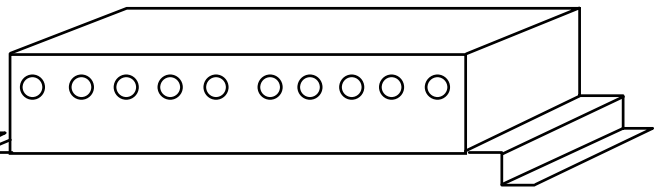

CM841 Junction Box

- |   |  |
|---|--|
| <ul style="list-style-type: none"> <li>• For 12 volt systems</li> <li>• Drive current: 20A</li> <li>• Can operate two parallel Controllers</li> <li>• Single Remote Port</li> <li>• Fluxgate or slave or digital heading</li> <li>• Footprint 204 x 136 mm</li> </ul> | <ul style="list-style-type: none"> <li>• For 12 - 24 volt systems</li> <li>• Drive current 30A max.</li> <li>• Dual Controller sockets</li> <li>• Dual Remote ports</li> <li>• Fluxgate or slave or digital heading</li> <li>• Footprint 256 x 136 mm</li> </ul> |
|---|--|

Figure 1.4 Comparison between Controller and Junction Box versions.

The shape of the final system is determined by the optional attachments and many combinations may be set up. Figs 1.5 shows a full system based on either the CM840 or CM841 Junction Box.

The core system components are shown with shading.

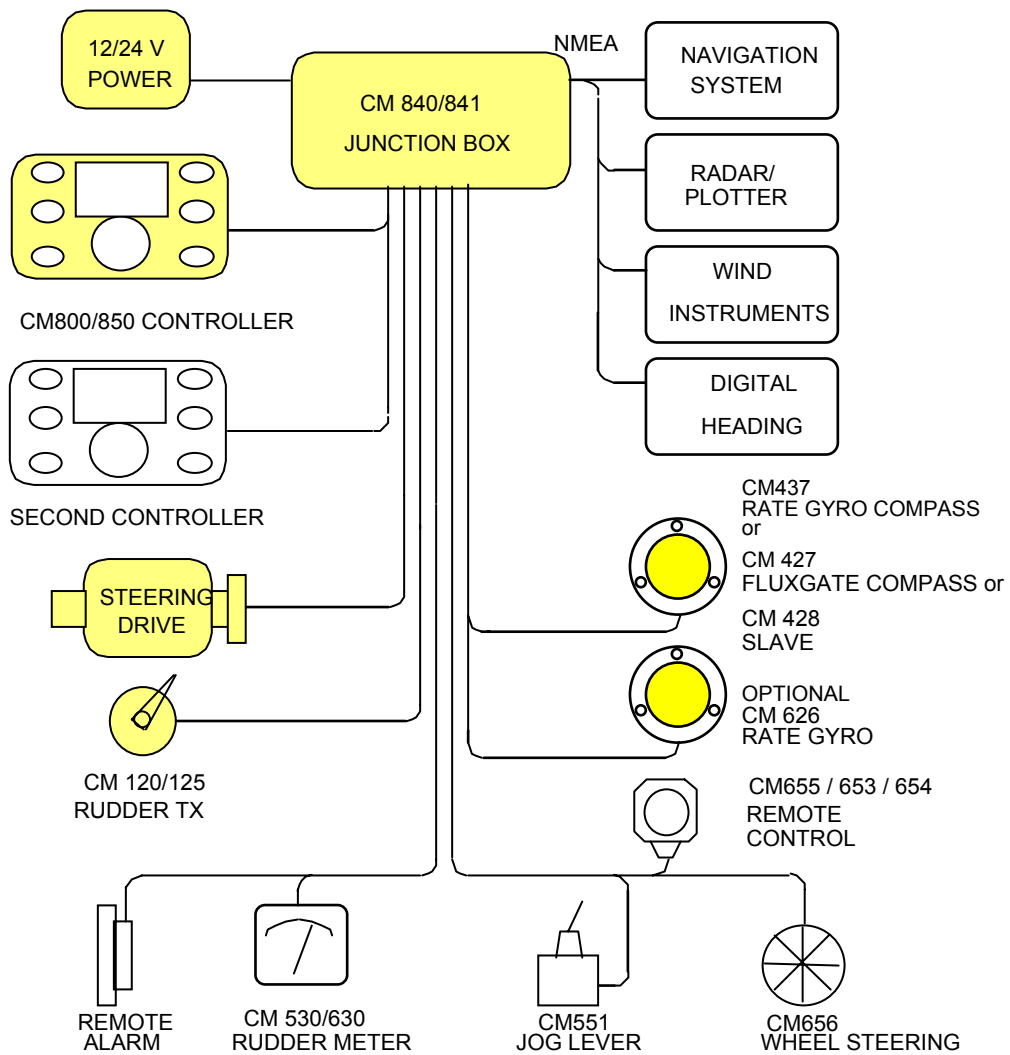

Figure 1.5 Autopilot system using the CM840 or CM841 Junction Box. Note that only one of the remote controls shown may be connected to a CM840 and that the CM840 operates only from a 12 V supply.

### CM840 or CM841 Junction Box

The Junction Box contains the control microcomputer, the interfaces with other system components and the steering drive electronics. All system cables are terminated in the

Junction Box. The drive system is robust and is designed to drive mechanical, hydraulic pump and solenoid controlled steering systems.

#### **CM800i or CM850i Controller**

The Controller has six push-buttons to control the system and displays information on the current operation of the autopilot.

#### **Compass Options**

The CM437 Rate-Gyro Compass combines a fluxgate compass and rate gyro in a single package. This combination should give the best steering performance over a wide range of conditions. Alternatively, the CM427 contains just a fluxgate compass. Both use a floating toroid sensor with built-in drive electronics.

#### **Rudder Transducer**

The standard rudder transducer is a CM120 which is suitable for recreational vessels. For commercial vessels, the heavy-duty CM125 is recommended. Both are fully sealed potentiometer types and are interchangeable.

#### **Steering Drive**

There are many mechanical or hydraulic steering options. A suitable drive may either be supplied by Coursemaster or the autopilot may be connected to an existing steering drive on the vessel.

### **1.3 OPTIONAL ATTACHMENTS**

#### **Rate Gyro**

The CM626 Rate Gyro is a vibrating crystal type which works in conjunction with the fluxgate compass or slave to give more precise steering control in all sea states. It provides a very stable short-term heading output which is independent of pitch and roll in the vessel. The fluxgate output is then used to correct for drift in the gyro so that long-term stability is also achieved. Using the rate gyro overcomes the 'southerly heading' softness encountered in the southern hemisphere, or the converse problem in the northern hemisphere. The rate gyro also quietens rudder activity in a heavy swell. This option is not relevant if a CM437 is fitted.

#### **Compass Slave**

If desired, the CM437 or 427 compass may be replaced by a CM428 compass slave mounted above the ship's card compass.

### **Remote Steering**

A number of remote steering options are available. The CM654 is a hand-held unit with a cable and the CM655 is a panel-mount version of the CM654. Both are fitted with a steering knob and a three-position switch (PILOT-STANDBY-HAND/REMOTE). The CM653 is a cable-connected remote without a switch. It comes into service automatically whenever the knob is turned away from the centre position.

The CM551 is a panel-mounted Jog Lever and the CM656 is heavy-duty steering wheel hub suitable for a full power-steer second station. Finally, a mode switch to switch between STANDBY and PILOT is available as a CM553.

One remote steering control may be connected to a CM840 Junction Box and two may be used with a CM841 Junction Box.

### **Second Controller**

A second Controller may be fitted. This may be either a CM800 or a CM850. Each Controller operates with equal priority. The system may be switched ON or OFF from either station and both Controllers show the same display.

### **Controller Mounting Kit**

The Controller(s) are supplied ready for dashboard mounting, but an optional bracket kit, CM705, is available for mounting it as a free standing unit.

### **Rudder Angle Indicator**

This indicator gives an analog display of the rudder angle and may be located either with the Controller or on another part of the vessel. It is available in two versions: CM530 and CM630.

### **Remote Alarm**

A piezoelectric beeper is available which repeats the internal alarms generated by the autopilot.

# CHAPTER 2 OPERATING INSTRUCTIONS

## 2.1 THE CONTROL PANEL

The front panels of the two Controllers (Figs 2.1 and 2.2) contain a text and graphics display, and course error lamps keys. The CM850i also has a course adjust knob, while the CM800i has an 'on course' indicator. The use of the controls is described in this chapter.

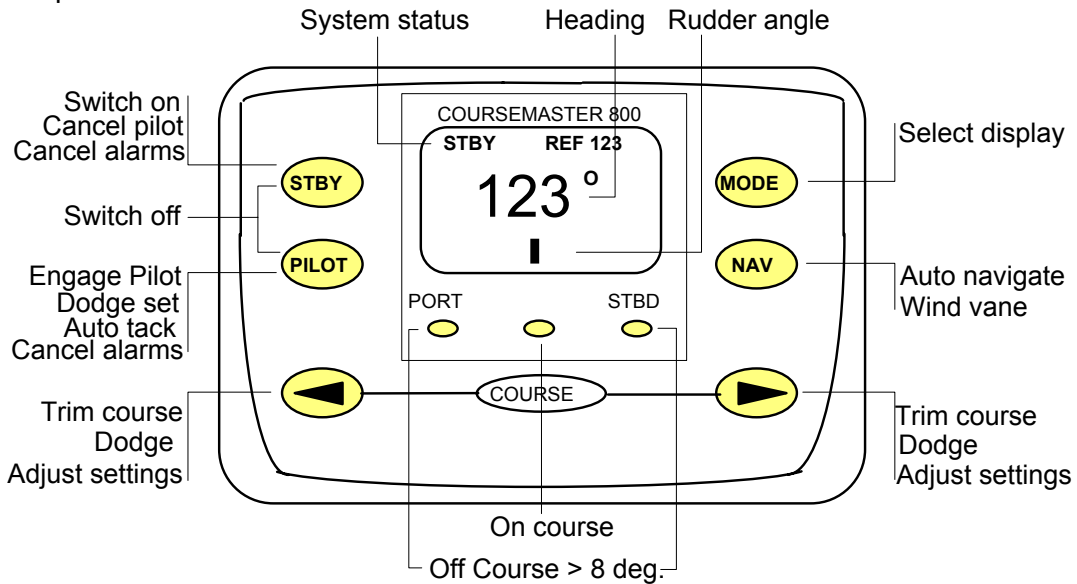

Figure 2.1 The CM800i Controller panel.

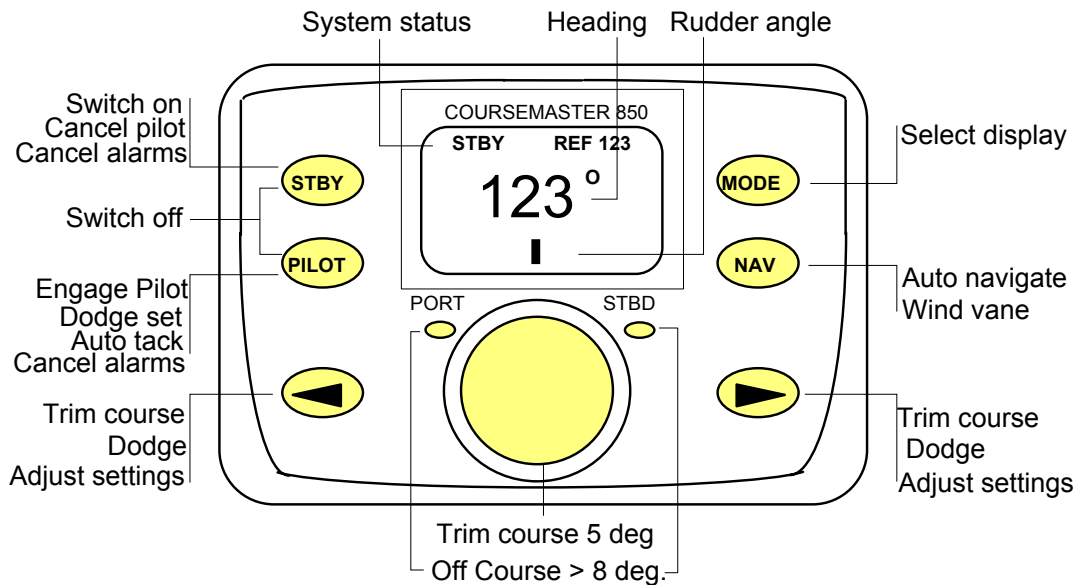
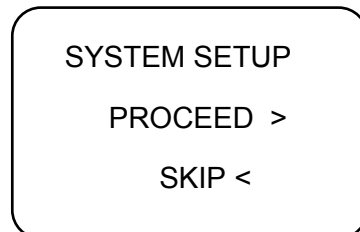

Figure 2.2 The CM850i Controller panel.

## 2.2 GETTING STARTED

Before operating the autopilot for the first time, it must be installed and adjusted as described in Chapter 3. (If optional attachments and interfaces are being used, these can be fitted after initial trials of the system.)

To switch on for the first time, press the STANDBY key. The system enters a set-up mode to ensure that the steering drive and rudder transducer have been phased correctly. After the SELF TEST display, the screen shows the system setup prompt:



There are two choices. If you wish to examine some of the features without carrying out the setup, select SKIP by pressing the left arrow. This will bypass the setup and let you scroll through the displays, but there will be no response to the PILOT key. The system will return to SYSTEM SETUP the next time it is turned on.

To carry out the setup, select PROCEED by pressing the right arrow.

The next two prompts enter a description of the vessel type, so that the auto-tuning program starts with values that are best suited for it. The Hull Type is set either to Displacement or Planing. Displacement hulls sit level in the water over their range of operating speeds. Planing hulls lift their bow clear of the water at higher operating speeds. Use the arrow keys to select between the two and press MODE. Then select a displacement (weight) in ton, which is close to the actual weight of your vessel, using the arrow keys to step up or down through the range of 1 to 110 ton. Then press MODE.

HULL TYPE  
DISPLACEMENT  
USE < OR >

DISPLACEMENT  
06 TON  
USE < OR >

The next two prompts are for storing the mechanical rudder limit positions and the rudder transducer phasing in the autopilot memory. The stored limits are set 4 degrees inside the actual stop positions and this ensures that no autopilot operations will push the steering drive right to the stops.

TURN HELM TO  
STBD LIMIT  
AND PRESS >  
04 P

TURN HELM TO  
PORT LIMIT  
AND PRESS <  
25 S

Turn the helm to starboard until it reaches the mechanical stop. The last line of the screen shows the helm angle. If it reads PORT instead of starboard, this will be corrected automatically when you press the right arrow key. Now press the right arrow key. Note that if the helm angle is less than 10 degrees at the stop, the system will not respond. After pressing the right arrow, the port limit prompt appears. Now turn the helm to port until it reaches the mechanical stop. At this stage, the helm direction will read correctly. Press the left arrow and the final prompt appears:

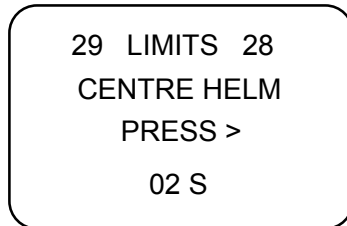

```
29 LIMITS 28
CENTRE HELM
PRESS >
02 S
```

The top line shows the stored values of the port and starboard rudder limits. Check that these are close to what you expect and are balanced within 5 degrees. Bring the helm to the position which your experience shows to be centred - the indicated angle may now be different from zero. Press the right arrow.

**Warning:** This action will start the steering drive. Make sure that it is safe to do so before pressing the right arrow.

Three things now happen. The current helm position is now placed in memory at the helm centre, the helm then moves to 10 deg port, pauses and then returns to centre. This operation corrects any small alignment errors in the rudder transducer, stores the correct drive phasing and completes the setup operation, returning the system to STANDBY.

Note that if the helm is not centred within 5 degrees, an 'Off Centre' alarm will occur and the setup will not continue. Press STANDBY and re-centre the helm by adjusting the rudder transducer. Later, when the vessel is at cruising speed, it is recommended that the HELM ADJUST option be used to fine-tune the helm centre. (Sec 2.5).

If a digital heading is to be used and a fluxgate compass is not connected, a 'Compass Fault' alarm will now appear. Select Menu 3 (See Sect 2.5), scroll down to the compass type option and select either the magnetic or true digital heading input.

## 2.3 NORMAL OPERATION

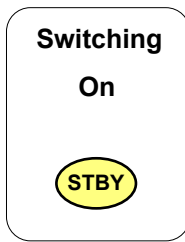

Press the STANDBY key. The system does a self-test for a few seconds and displays the version of software fitted to your autopilot. When the self-test is complete the normal STANDBY display appears and shows the current heading of the vessel.

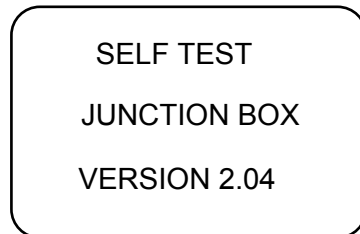

If a fault is detected during the self test, the Controller starts beeping and the nature of the fault is displayed after the self-test period.

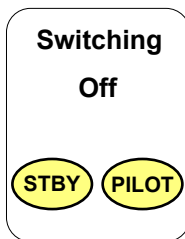

Press the STANDBY and PILOT keys together.

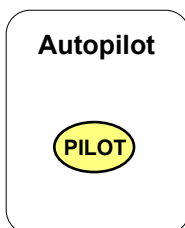

With the system in STANDBY, steer the vessel to the desired heading and press PILOT. The autopilot will now lock onto that heading and maintain it. The position of the rudder when the PILOT key was pressed is stored in memory as the effective helm centre. The display will show 'PILOT' in the top left corner.

### CM800i Controller

To adjust the current reference course, press either the left or right arrow key. A single press changes the course by 1 degree. Holding a key down changes the course continuously in 10 degree steps.

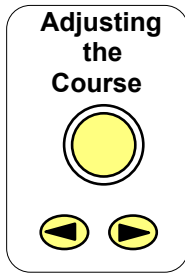

### CM850i Controller

Turning the COURSE knob changes the reference course in 5 degree steps. For finer adjustments, use the left and right keys to change in 1 degree steps.

**Note.** In the auto navigate mode the reference will not change, since it is controlled by the GPS system.

### Dodge

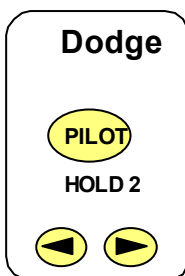

The dodge function is used to make a quick course change to avoid an obstacle. Hold the PILOT key down for two seconds, a beep will sound and the dodge message appears in the top left hand side of the display. Release the key and press the left or right arrow keys to run the helm out. When the arrow key is released the helm holds its current position. To return to the original course, press PILOT.

### Autotack

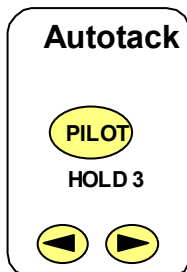

The autotack feature produces a delayed course change which is useful for single handed sailing. Hold the PILOT key down for the beep after the DODGE prompt and the screen shown on the left appears:

AUTOTACK 100  
PRESS < OR >

AUTOTACK 100  
COUNTDOWN 8

The number on the top line shows the angle through which the vessel will turn. This may be adjusted in the Menu (Sec 2.5).

Press one of the arrow keys for the direction of the course change and the countdown will start. At the end of the 10 second countdown, the vessel will steer to the new course. To cancel the autotack during countdown, press STANDBY or PILOT. As with the

course change function, autotack will not work when in the auto-navigate mode.

If operating with a wind instrument input, the operation is slightly different. The top line of the display shows 'W V' in place of the turn angle and when it turns the new heading sets up the same relative wind angle on the opposite side of the vessel. The turn direction is through the shorter arc.

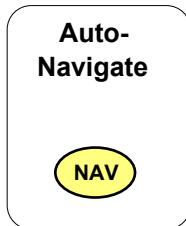

If a GPS receiver or other source of navigation data is connected, the vessel can be steered to head towards a waypoint with minimum cross-track error. Press the NAV key once to turn on auto navigation. Press it again to turn it off.

If only heading-to-steer data is being received, the top right of the display shows this heading, eg.

**NAV 123**

If the crosstrack error is also being received, the vessel steers to minimise the error and the top right of the display alternates between the heading-to-steer and the crosstrack error, eg.

**XT 0.07 L**

If NMEA data is not being received, the top right of the display reads:

**NAV WAIT**

and the vessel will continue to hold the previous reference course. If this message does not clear within 15 seconds, consult the NMEA installation section of Chap 3.

**Remote  
Steering**

If a Remote Helm or similar attachment is fitted, switching it to the HAND mode overrides normal autopilot functions and provides direct rudder control. In this mode, the display shows REM or JOG in the top left corner. (With a CM841 Junction Box, attachments to the second port produce REM 2 or JOG 2 in the display.

For remote controls with a knob and a switch (CM 654, CM655) and wheel steering (CM656), REMOTE is activated by switching to REMOTE. The rudder angle now follows the knob position. When it is switched back to PILOT, the current heading becomes the reference, or in NAV mode it reverts to the GPS heading to steer. For the unswitched remote control (CM 653), moving the knob away from the centre automatically put the system in REMOTE and it returns to PILOT when the knob is centred. For a jog lever (CM551), moving it places the system in REMOTE and runs the helm out until the lever is released. When it is released, the helm stays in that position. The system is returned to PILOT by pressing the PILOT key.

The CM800i system responds to the most recent input from either the control panel or a remote attachment. Therefore, when the system is turned on, the setting of all remotes is ignored until some input is made to them. Similarly, pressing STANDBY or PILOT on the control panel will override a remote. If two remote attachments are fitted, the system responds to whichever has been used most recently. There is a menu option to disable any remote response unless the system is in PILOT.

**Wind Vane  
Steering**

A rectangular button with a yellow oval in the center containing the text "NAV" in black. Below the oval, the word "HOLD" is written in black.

If a wind instrument is fitted, steering to the wind is activated by holding down the NAV key for 2 seconds. When data is being received, the top right display shows the relative wind angle, eg:

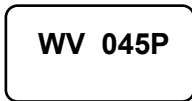
A rectangular display box containing the text "WV 045P" in black.

The vessel now holds a fixed relative heading to the wind, being the one existing when the NAV or PILOT key was pressed. The relative heading may be adjusted via the course knob or by returning to STANDBY and hand steering the vessel to a new course. If data is not being received, the display shows **WV WAIT**.

To cancel the wind vane mode, press NAV.

## 2.4 THE MODE KEY

The MODE key provides for adjustment to the steering settings, access to the navigation data and access to the programming menus.

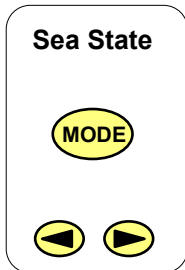

Press the MODE key once. The display shows the current control mode setting.

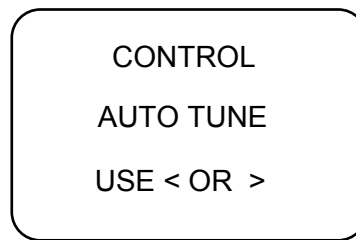

Press one of the arrow keys to select the desired control mode from the following (for further information, see Sec 2.7):

### **AUTO TUNE**

Auto-tune is the standard setting for the autopilot. When selected, no further adjustment should be needed during use. However, there may be situations where you wish to operate with fixed tuning and the following manual choices may be selected.

### **NORMAL**

Direct proportional control with a counter-rudder component that be adjusted from the menu (see below). More information on manual settings is given in Sec 2.7.

### **ROUGH**

This suits most vessels in heavy conditions. The control has a deadband which permits a 5 deg yaw about the reference course before correction is applied. Outside this window, the control is as for

the Normal mode. Rudder activity and power consumption are therefore kept to a minimum.

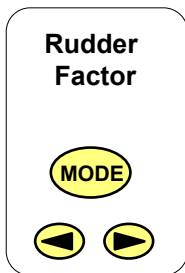

Press MODE twice to adjust the RUDDER FACTOR. This may be increased or reduced using the arrow keys. In the auto-tune mode, this value is the 'starting point' which applied when the pilot key is pressed. As the vessel travels, the effective rudder factor is internally adjusted above or below this point. In the two Manual modes, this setting becomes the fixed rudder factor. There is more about the rudder factor in Sec 2.7.

The control mode and rudder factor displays time out if a key is not pressed and the pilot returns to the standard display.

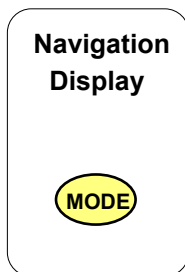

Press the MODE key three times brings up a screen which displays navigation data received from the GPS or other device, eg.

WAYPOINT	003
RANGE	26 NM
LAT	23 47.218 S
LONG	137 18.330 E

Not all of this data may be received from a given NMEA system, and part of the screen may therefore be blank. This data is displayed for user convenience and does not affect the operation of the autopilot. If no data relevant to this screen is being received, the message 'Waiting for Data' is shown.

## 2.5 PROGRAM MENUS

Three program menus give access to a number of system settings which may be used to fine-tune the performance and select various options. Adjusted settings are stored in permanent memory and are retained while the system is turned off. Hold the MODE down for 2 - 3 seconds and the screen will show:

MENU 1	MODE
MENU 2	>
MENU 3	<

The content of the three menus is shown below. Select one by pressing MODE or one of the arrow keys. The active menu option is marked with >. Use short presses of the MODE key to scroll down. To exit the menu, press the STANDBY or PILOT key. The active menu option is adjusted by pressing the left or right arrow keys.

The contents of the three menus is shown below.

<p>MENU 1 USE &lt;&gt;</p> <p>&gt; BACKLIGHT 2</p> <p>RATE GYRO OFF</p> <p>HELM ADJ 02 P</p> <p>HEAD ADJUST 001</p> <p>AUTO COMP CAL</p> <p>MAN COMP CAL</p> <p>COLD START</p>	<p>MENU 2 USE &lt;&gt;</p> <p>&gt; RUDDER LIMIT 20</p> <p>HELM DAMPING 2</p> <p>HELM DEADBND 1</p> <p>RATE FACTOR 2</p> <p>HELM ALERT 0</p> <p>TACK ANGLE 100</p> <p>VARIATION 013</p> <p>AUTOTRIM 1</p>	<p>MENU 3 USE &lt;&gt;</p> <p>&gt;HEADING FLUXGATE</p> <p>NMEA OUT HDG</p> <p>STALL ALARM ON</p> <p>REMOTE LOCK OFF</p> <p>TUNE MONITOR</p> <p>STEER DRIVE</p> <p>COMPASS MONIT</p>
--	--	---

### Menu 1

#### BACKLIGHT

The backlight for the display can be set to 4 different brightness levels. Use the arrow keys to adjust.

#### RATE GYRO

If a CM437 is fitted or a CM626 rate gyro has been fitted as an optional attachment, the gyro function is turned on or off via the arrow keys.

#### HELM ADJUST

For best overall performance, it is important that the displayed rudder angle be adjusted to read zero when the helm is dead ahead. This adjustment compensates for errors in the transducer linkage and other offsets in the steering gear. The current helm

angle is displayed and should read 00 at the centre. Use the arrow keys to trim the reading.

## **HEADING ADJUST**

The current fluxgate heading is displayed and compass mounting errors may be compensated using the arrow keys.

## **AUTO COMPASS CALIBRATION**

This is one of two options to reduce deviations caused by magnetic components and material on the vessel. To carry out this calibration, press the right arrow. The display reads:

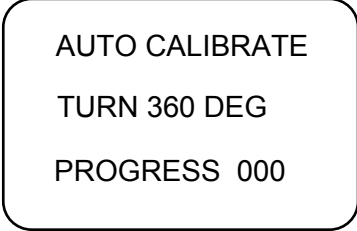

AUTO CALIBRATE  
TURN 360 DEG  
PROGRESS 000

With the vessel under way and steering it by hand, turn it slowly through a full circle. You may turn either to port or starboard, but the same direction should be maintained until the circle is complete. The progress display shows the angle turned through so far. When the circle is complete, the display shows the calibration results, eg.

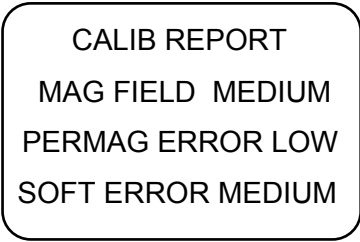

CALIB REPORT  
MAG FIELD MEDIUM  
PERMAG ERROR LOW  
SOFT ERROR MEDIUM

Line 2 rates the overall strength of the earth's field at the compass as low, medium or high. A high reading should be seen at the equator and medium or low from 20 degrees or more away from the equator. Line 3 rates the level of error produced by magnetised material in the vessel and Line 4 rates the error produced by

concentrations of soft iron in the vessel. The results are for guidance only as there are interactions between the three ratings. Sec 3.3 gives more information on optimising compass performance.

Press STANDBY to return to normal operation. This method of calibration is simple and is a recommended procedure for all vessels. However there are some magnetic anomalies which are not fully removed. The manual calibration option provides a further refinement of compass accuracy.

**Note.** If a rate gyro is fitted, it is turned off automatically by selecting the calibration option and should be turned on again when calibration is complete.

## MANUAL COMPASS CALIBRATION

Manual calibration can be carried out independently of auto calibration, but is best done after an auto calibration procedure. Press the right arrow for the following display: (All settings are initially zero after an auto calibration, but the settings from any previous manual calibration are shown.)

HEADING	225
+00	+00
+00	+00
+00	+00
+00	+00
+00	

Turn the vessel to a heading which is close to one of the cardinal or inter-cardinal points, ie.

000, 045, 090, 135, 180, 225, 270, or 315.

Then use the arrow keys to adjust the deviation up or down until the heading agrees with that of the ship's compass or other reference compass. Turn to the next point and repeat the procedure until all eight have been checked or adjusted. Press STANDBY.

Manual calibration may be fine-tuned at any time by selecting this function and turning, for example, to just one cardinal point which may need adjustment. Note that all calibration settings are cleared when a COLD START is carried out.

## **COLD START**

This option restores the original factory preset parameters in the autopilot and should be used if there has been some malfunction or if new software has been installed. When the prompt appears, press the right arrow. After the presets have been re-loaded, the screen shows:

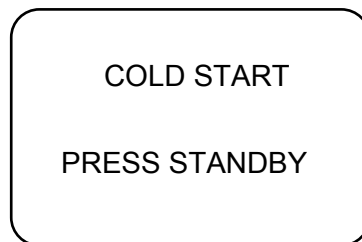

## **MENU 2**

### **RUDDER LIMITS**

This setting controls the maximum rudder angle used when the system is in PILOT mode. It is preset to 20 degrees and may be changed using the arrow keys. It should always be less than the mechanical limits stored during the System Setup procedure.

### **HELM DAMPING**

The Helm Damping control compensates for inertia or overshoot in the steering drive, which may be present in most hydraulic or electrical systems. To check the suitability of the preset value of 2, turn the helm manually to about 20 deg. rudder angle and press PILOT to centre the helm. Observe the rudder movement. If the rudder stops short and then "inches" into the centre position, reduce the damping factor. If it overshoots and "inches" back, increase the damping factor.

### **HELM DEADBAND**

The deadband acts as a filter which prevents the steering drive from pulsing on and off in response to very small error signals. If it is set too high, the steering will be slow to respond to small corrections. The best setting is one just above the value which produces continuous pulsing of the steering gear.

**RATE FACTOR**

The RATE FACTOR controls the amount of counter rudder applied in all control modes. Guidelines for setting it are given in Sect 2.7.

**HELM ALERT**

As a safety feature, a HELM ALERT alarm is activated at regular intervals when the system is in the PILOT mode. The time interval may be set to 5, 10 or 15 minutes or the alert may be switched off.

**TACK ANGLE**

In auto-tack mode, the angle through which the vessel turns may be set in 5 degree steps from 20 to 160 degrees.

**ADJUST VARIATION**

A magnetic variation value must be entered if GPS sentences containing TRUE headings are used. The variation is displayed on a 360 degree scale, i.e. 13 degrees east appears as 013, while 10 degrees west appears as 350. Use the COURSE keys to adjust the variation.

**AUTOTRIM**

The autotrim continuously adjusts the helm centre by averaging the course errors over time. It may be switched off (0) or on (1).

**MENU 3****COMPASS TYPE**

This allows a selection between a heading input from a fluxgate compass (or slave) and a digital heading input via one of the NMEA ports. There are two digital heading options: a magnetic heading (HDG) or a true heading (HDT). If the true input is used, a T symbol appears on the right of the working display and all navigation headings are shown as true.

**NMEA OUTPUT**

The NMEA heading output may be selected between HDG (magnetic) and HDT (true). Some version may also show a SIM option. This is for factory testing and is not used in an installed pilot.

**STALL ALARM ON**

The Drive Stall alarm is activated after a Cold Start, but this option may be used to disable it, if necessary. We recommend that it not be disabled for normal use.

**REMOTE LOCK**

If the Remote Lock is switched on, the system will only respond to a remote steering attachment when it is in PILOT.

**TUNE MONITOR** For technician use to check the operation of the automatic tuning.

**STEER DRIVE** This may be used to run the steering drive continuously for bleeding purposes. Note that if the rudder transducer is not coupled, there is a risk of driving the steering gear against the stops. Press the left or right arrows to start and stop the drive.

**COMPASS MONIT** Used to measure fluxgate output voltages for diagnostics.

## **2.6 ALARMS**

The CM800i System has a number of alarm functions. When an alarm occurs, the beeper sounds and an alarm message appears on the display. To cancel an alarm, press the STANDBY or PILOT key. If the system is in PILOT and this key is used to cancel an off-course alarm, for example, the reference course is not changed.

**OFF COURSE** The vessel has been more than 8 deg off course for 30 seconds. This only operates in the PILOT mode and while the alarm is active, all other functions operate normally. Cancel it by returning to course or pressing the STANDBY or PILOT key.

**HELM ALERT** In PILOT mode, the helm alert operates in three stages. One minute before the preset time (5, 10 or 15 sec.), the HELM ALERT message flashes on the display without the beeper sounding. At the preset time the message is on continuously and the internal beeper sounds. One minute later, the external alarm sounds. The alarm is cancelled and reset by the PILOT or STANDBY key.

**DRIVE OVERLOAD** The current drawn by the steering gear has exceeded the limits and the drive has been turned off. See Chap. 4 for further information.

**DRIVE STALLED** If the steering drive is activated and the helm moves less than 1 degree in 2.5 seconds, the system is switched to STANDBY and this alarm is set.

**RUDDER OVER RANGE** Either the rudder has travelled past the limits set during System Setup or an electrical fault has developed in the Rudder Transducer. The system switches to STANDBY.

- COMPASS FAULT** If a fluxgate compass has been selected, the magnetic field being sensed by the compass is above or below preset limits. Further information is given in Chap. 4.
- NO HEADING DATA** If a digital heading input has been selected, a valid heading sentence is not being received.
- OFF CENTRE** This alarm is only used during the setup procedure and occurs if the helm is not correctly centred for the last stage of the setup.
- SYSTEM FAULT** This alarm is generated by the Controller to indicate that no data is being received from the Junction Box. This can indicate either a fault in the Controller cable or a failure within the Junction Box.

## 2.7 RECOMMENDED SETTINGS

As previously stated, in the auto-tune mode, internal settings are preset during the setup procedure and are then adjusted automatically while under way. There may be cases where you wish to change these presets via the menu, but generally the guidelines below are for use in the manual modes.

The **Rudder Factor** is set according to the responsiveness of the steering. Yachts and power boats from 6 to 15 m in length, generally have responsive steering and a rudder factor setting of 3 or 4 is suitable. For high speed planing hulls, a setting of 2 to 3 should give better control. Vessels above 15 m length normally have less responsive steering and a good rudder factor setting is in the range 5 to 7.

A rudder factor of 4 applies 0.5 degree of helm for each degree off course.

**Autotrim** is normally turned on.

The **Rate Factor** compensates for turning inertia in the vessel and its choice is affected by both the displacement of the vessel and its directional stability. If 10 degrees of helm is applied and the turn is established within 1 to 3 seconds, then a Rate Factor of 2 is suitable. If it takes 5 to 10 seconds to reach the full turn rate, then a setting of 4 or 5 is suitable. Setting the Rate Factor too high can produce excessive rudder activity and slow down the completion of a course change. Setting it too low produces over-shooting during course change.

## CHAPTER 3 INSTALLATION

Before proceeding with the installation, check the contents of the shipment to ensure that all components ordered are present and undamaged. If a steering motor or hydraulic drive is included, check that its voltage rating is suitable for the vessel's supply. Read all of this chapter before starting and then follow this step-by-step guide:

1. Mount the Junction Box as described in Sect 3.1. Take care that the polarity of the battery wires is correct and that the metal parts of the terminal blocks grip the wires and not the insulation.
2. Mount the Controller as per Sect 3.2.
3. Mount the Compass as described in Sect 3.3. Take care to keep it away from the sources of magnetic interference.
4. Mount the Rudder Transducer as shown in Sect 3.4. Ensure that the linkage geometry is correct and if it is in a storage area, ensure that heavy objects will not fall on the linkage.
5. Install and connect any additional attachments as described in Sect 3.5. (Or, if preferred, these could be installed after initial commissioning.)
6. Install the steering drive as described in Sect 3.6
7. Apply power to the Junction Box. Now turn to Section 2.2 of this Manual - Getting Started - and carry out the initial setup.

### 3.1 JUNCTION BOX

The Junction Box should be mounted on a vertical surface with the cable entry holes facing downwards. It should be protected from the weather and be well above the bilge water level in the vessel. Do not mount it in the engine room or other high-temperature location. Two further considerations are that the connection sockets be easily accessible when the lid is removed and that there is a space of at least 50mm on all four sides to permit air circulation. (The outer case forms a heat sink for the internal power components). Fix the case using screws through the two mounting flanges. To open the case, remove the four screws holding the cover flanges to the base and lift the cover. Before commencing the wiring, isolate the vessel's power bus from the power supply. Note that all connections to the Junction Box, except for motor and power, are made to removable plugs. Figs 3.1 and 3.2 show the location of the sockets and principal components for the CM840 and CM841, respectively.

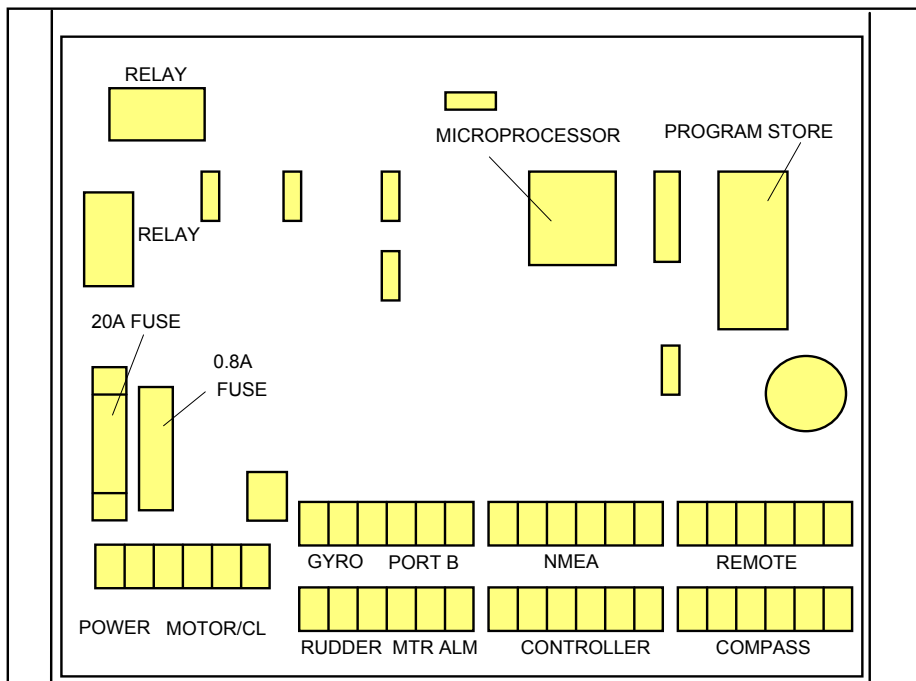

Figure 3.1 Layout of CM 840 Junction Box components and connectors.

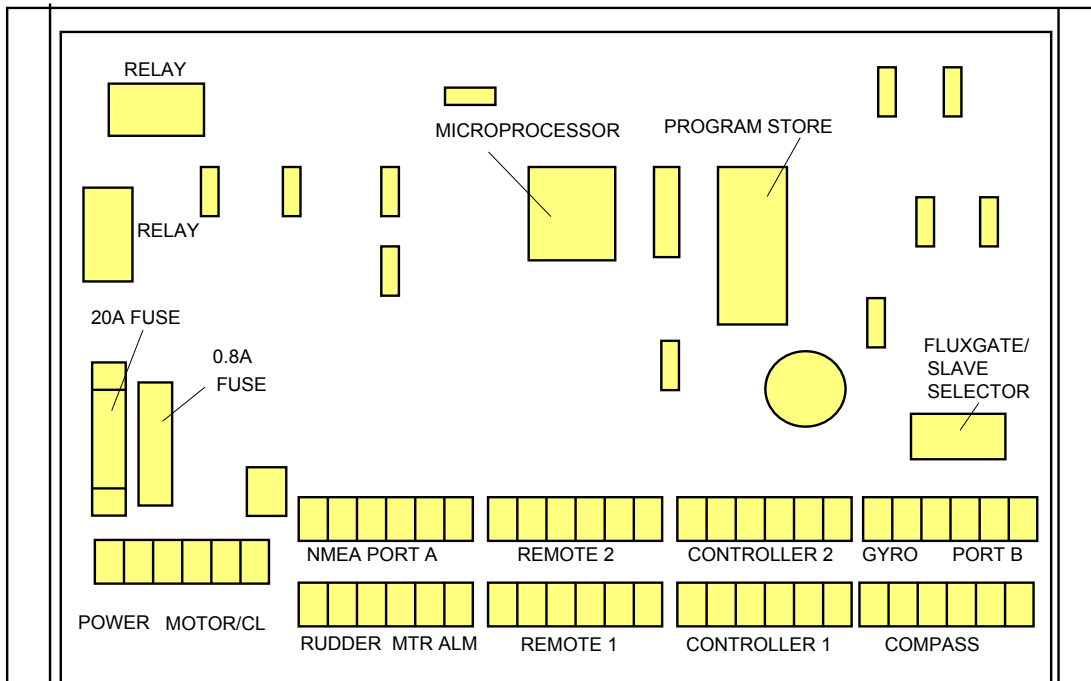

Figure 3.2 Layout of CM 841 Junction Box components and connectors.

**Note:** The fluxgate/slave selector switches are fitted to suit an earlier model of compass slave (CM418). Current systems are supplied with a an optional CM428 slave whose output is the same as a fluxgate. Therefore, these selector switches should be left in the fluxgate position, even if a compass slave is fitted.

The quality of the power supply to the Junction Box is important for reliable operation. Large voltage spikes caused by switching other electrical gear on the vessel, or the supply voltage moving outside the specified limits can cause the system to reset. These problems are reduced by using heavy wiring and connecting the system to a point as close as practical to the main batteries.

Lay a 30 amp twin-core cable to the vessel's power bus, slipping a grommet over the cable where it enters the Junction Box and connecting the cable to the terminal block. It is also recommended that a 20 or 30 amp switch is installed between the Junction Box and the power bus so that the autopilot can be isolated during unattended periods.

### 3.2 CONTROLLER

The Controller may be mounted in any convenient position. Although the front of the controller is weather-proofed, it should not be mounted where it is exposed directly to rain or spray. The cable plug and socket at the rear of the case are not weather-proofed.

There are two mounting options: it may be trunnion mounted or flush-mounted. For trunnion mounting, attach the optional pivot bar (CM705) to the rear of the case, using the two screws provided and mount the bracket on a suitable surface. For flush mounting, drill the mounting surface with two holes to take M 5.0 mounting screws and with one 24mm hole to take the cable plug. The Controller is simply fixed from the rear and there is no need to make a cut-out in the panel.

Lay the Controller cable back to the Junction Box, feed it through a grommet into the case and terminate the wires and cable screen in the Controller plug. Tighten each grub-screw firmly. If the cable is to be shortened, cut it at the end closest to the Junction Box, since the plug connection at the Controller end cannot be re-made. Allow enough spare cable length to accommodate a change in the component positions at some later date. After cutting, strip each wire before connecting it as shown in Fig 3.3. Check that the insulation is not caught in the terminal clamps and plug the cable into the socket at the rear of the Controller case.

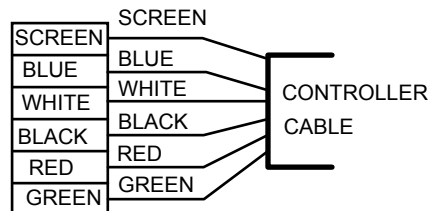

Figure 3.3 Controller cable connections.

To minimise the risk of radio interference, the Controller cable, like the others, must be kept well separated from antennas and antenna feeds. On some vessels this is difficult to do, but some extra effort to maintain separation will reduce problems in the future.

### 3.3 COMPASS

The performance of the compass affects the performance of the whole system and some care should be taken in locating it in the best position. If a compass slave, mounted on the glass face of the ship's flat top compass, is being used, performance is mainly dictated by the accuracy of the ship's compass. If a CM437 rate-gyro

compass or a CM427 fluxgate compass is being used, the following guidelines should be followed.

Ideally, the compass should be mounted at the roll centre of the vessel, at or slightly above the waterline. The unit may be damaged by long-term exposure to water and must be above the bilge level. It should be at least 1 metre away from the engine and from other objects with strong magnetic fields such as loudspeakers and wiring which carry large currents. In timber, fibreglass or aluminium hulls, these conditions should be easily met. But in steel hulls, some trial and error may be needed to find the best position. Generally, the compass will not perform well if totally enclosed in a steel structure. Further notes on mounting in a steel vessel are given below.

Mount the CM437 or CM427 compass on a vertical surface with its mounting flange towards the bow and the cable entry facing down. (The compass will not operate correctly if mounted upside down.) Corrections for small errors in orientation can be made via the heading adjust menu option in the autopilot. Lay the cable back to the Junction Box, following the same method and precautions as for the controller cable and terminate it in the Compass socket as shown in Fig 3.4.

The CM437 cable has 6 conductors, plus a screen. Five of these are connected to the Compass socket, as in Fig 3.4(a). The sixth (brown) is connected to the brown pin on the Gyro/Port B socket. For the CM427, the 5 conductors are connected to the Compass socket as shown in Fig 3.4(b).

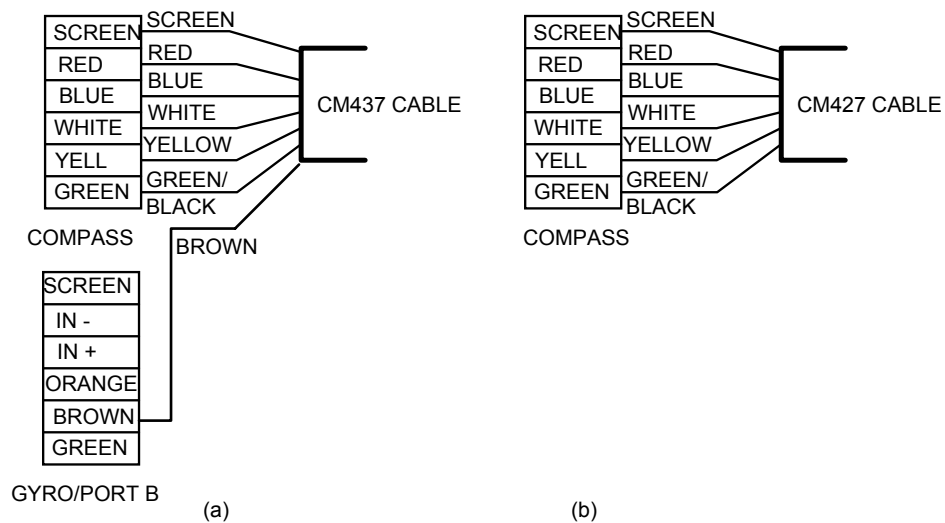

Figure 3.4. Socket connections for (a) the CM437 rate-gyro compass and (b) the CM427 fluxgate.

The CM428 compass follower/slave has the same cable connections as the CM427 fluxgate (See Fig 3.5). As previously mentioned, the selector switches in the CM841 Junction Box should be left in the fluxgate position in all cases.

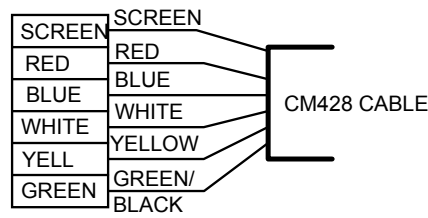

Figure 3.5. Socket connections for the CM428 compass slave.

### Steel Vessels

Steel hulls distort the natural pattern of the earth's magnetic field. In many cases these deviations can be adjusted out through the calibration procedures. In others, a strong vertical field component may exist which will prevent the compass giving good performance. It is recommended that the compass be mounted temporarily so that the best site can be found by experimenting. The following notes should help find the best mounting:

1. In the first instance, try siting the compass unit below decks but centrally within the vessel. Keep well clear of vertical steel bulkheads and position the compass at least 45 cm (18 in) above a steel floor.
2. As an initial check, complete the other steps in the installation and turn the autopilot onto STANDBY. (The rate gyro option must be turned off for this test.) Turn the vessel through a full circle, noting at 45 deg. intervals the difference between the heading displayed and a reference (eg ship's) compass.

Should the deviations exceed 30 deg. in any position, keep re-siting the compass until a position giving less than 30 deg. error is found. If errors still exceed 30 deg., the compass should be mounted above deck level, preferably in the dog house near a window. If this is done, repeat (2) above.

If no position is found giving less than 30 deg deviation, the services of a compass adjuster should be sought. The autopilot will not operate satisfactorily with compass deviations above 30 deg. A compass calibration (See Sec 2.5) is recommended after the installation is complete.

### 3.4 RUDDER TRANSDUCER

Mount the rudder transducer next to the rudder post. The transducer should normally have its arm uppermost, but may be inverted if this is more convenient. The linkage schematic is shown in Fig 3.6. When fitting it is important that the effective lengths of the transducer arm and the quadrant or tiller arm (marked D2) be equal to each other and that the link rod be the same length as the spacing between the transducer and rudder post (D1). This is to ensure that the transducer angle tracks the angle of the rudder. Mount the transducer so that its arm is over the cable entry point when the rudder is centred.

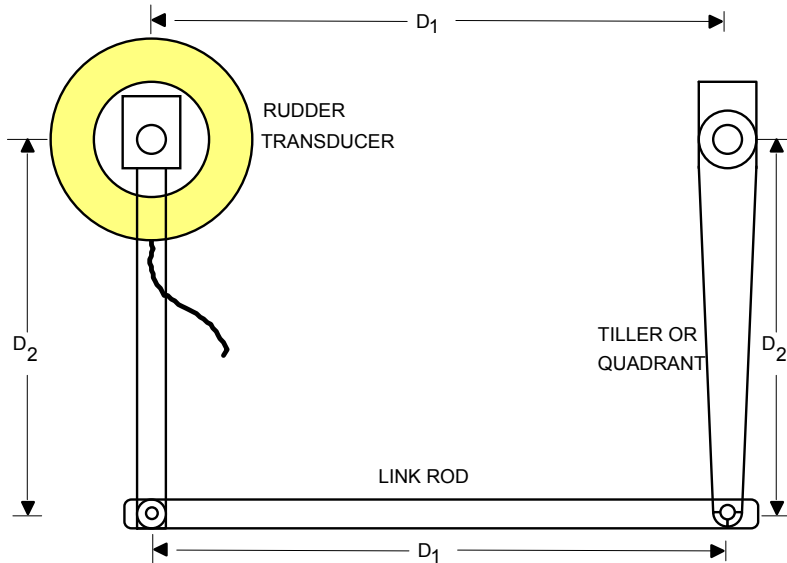

Figure 3.6 Rudder Transducer Linkage

Lay the cable back to the Junction Box and terminate it in the Rudder Transducer plug as shown in Fig 3.7.

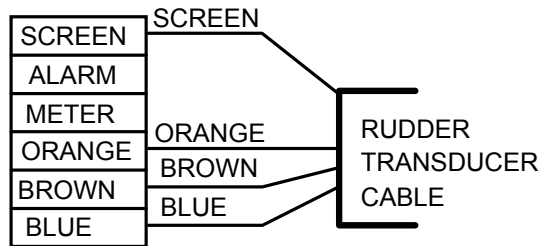

Figure 3.7. Rudder transducer connections.

When carrying out the setup procedure (Sec 2.2) at a later stage, it may be necessary to adjust the zero position of the transducer. To do this, loosen the clamp holding the transducer arm. Very slowly rotate the shaft with a screwdriver until the reading is correct. A small turn of the shaft makes a big difference to the centre.

### 3.5 ATTACHMENTS

#### 3.5.1 REMOTE STEERING

The CM 840 Junction Box has one Remote port and the CM841 has two Remote ports. In the latter case, there is no preference which attachment should be connected to which port. Most of the of remote steering options use a five-wire cable, which is connected as shown in Fig 3.8(a). The CM551 Jog lever uses a three-wire cable and is connected as in Fig 3.8(b). The three-wire CM553 switch is connected according to Fig 3.8(c) below.

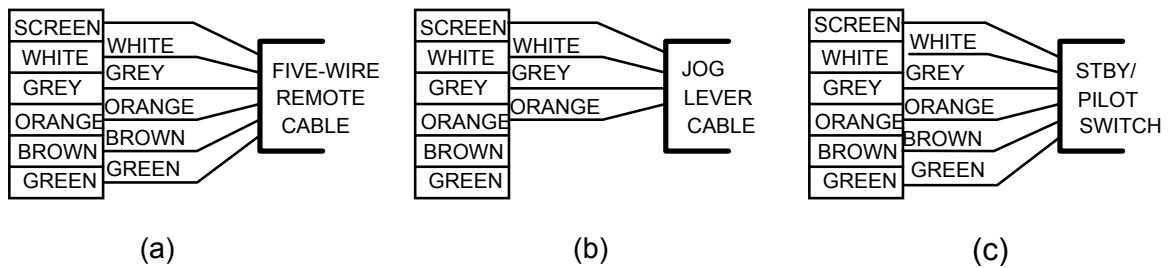

Figure 3.8. Remote attachment connections for (a) Five-wire Remotes, (b) Jog Lever and (c) STBY/PILOT switch.

Note that if a non-Coursemaster switch is used for the STBY/PILOT function, it is connected to grey, orange and green, but it is necessary to fit two 4.7Kohm resistors between orange and brown and between green and brown at the socket.

#### 3.5.2 RATE GYRO

The CM626 Rate Gyro would only be fitted as a supplement to the CM427 fluxgate compass. If a CM437 is used, the rate gyro function is included within the 437. The CM626 is supplied in a similar housing to the fluxgate and should be mounted on a vertical surface, in an area free from engine vibration, with its cable gland facing down. Otherwise, no precautions are needed with respect to magnetic fields. The gyro has a three-wire cable which connects as shown below.

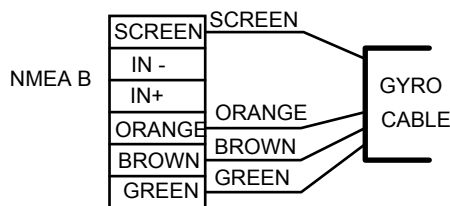

Figure 3.9 Rate Gyro connection.

#### 3.5.3 SECOND CONTROLLER

A second Controller, which is either a CM800*i* or CM850*i* unit, is mounted as for the first Controller. In a CM840 Junction Box, it connected in parallel to the first Controller cable. For the CM841 there is a separate socket for the second Controller.

### 3.5.4 RUDDER ANGLE INDICATOR

The CM530 and CM630 Rudder Angle indicators are two-wire meters which are connected between the METER and ORANGE terminals of the Rudder Transducer socket in the Junction Box. The polarity of the connection may be changed to obtain the correct direction of indication.

### 3.5.5 REMOTE ALARM

A piezoelectric beeper is available which repeats the internal alarm and key beeps of the Controller. This two-wire unit is connected between the ALARM (positive) and GREEN (negative) terminals of the Rudder Transducer socket. Any beeper may be used which is compatible with the drive available of 35mA (max) at 10.5V dc.

### 3.5.6 NMEA INTERFACES

The Junction Box has two NMEA input ports for navigation, wind and heading data. There is also one output port for heading data. Both input ports are sampled continuously so that a given cable can be connected to either. But two cables must not be connected in parallel to one input. The Port A socket is shown in Fig 3.10, while the Port B input, which is shared with the gyro, was shown in Fig 3.9.

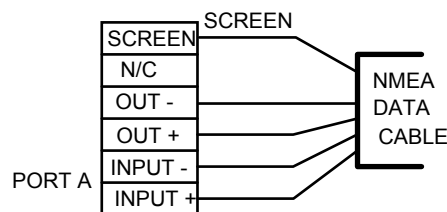

Figure 3.10 NMEA data cable connections.

The correct polarities are such that when the external NMEA system is transmitting, the wire that goes positive is connected to the + terminal of the input pair. After the connection

is made, complete the other parts of the installation before checking for correct reception, as follows:

Turn the system on and select PILOT. Press the NAV key. The top right of the display may now show:

### **NAV WAIT**

and may remain for up to 15 sec. If it stays longer, there is some fault with the interface. Try reversing the input wires. Then check that the NMEA device has also been set up correctly and that a waypoint has been entered. If it is a GPS receiver, the message being sent will be read as invalid if the GPS has not acquired the required number of satellites or there is no destination waypoint. Details of the navigation sentences accepted by the system are in Chap 5. Note that, if two NMEA inputs are connected and both contain a navigation sentence, the data in these two sentences must be the same.

The NMEA output port sends an HDG sentence containing the current magnetic heading.

## **3.6 STEERING DRIVE**

Four options are covered in this section: electric motor drive to mechanical steering, coupling into a motor-drive hydraulic system, coupling into a solenoid-controlled hydraulic system and a hydraulic linear drive. For existing hydraulic systems using a helm pump, instructions are given below for adding a Coursemaster/Hydrive pump motor. But for systems supplied by other manufacturers, installers should consult the data supplied by the manufacturer.

Through the wide variety of possible drive systems and the load placed on them, the goal is to move the rudder from 20 deg port to 20 deg stbd in not more than 15 sec. and not less than 8 sec. Steering systems which perform outside these limits may not give satisfactory autopilot operation.

### 3.6.1 CHAIN DRIVEN MECHANICAL STEERING

The drive sprocket on the steering motor matches 12.7mm (1/2 inch) British Standard simple chain. The size of the driven sprocket on the steering wheel is chosen to give the recommended helm response time for the length of the hull. The sprocket size is chosen from Table 3.1 or 3.2 below, depending on the voltage. If the sprocket is mounted on an intermediate shaft in the steering system, the 'wheel revolutions' in the table apply to that shaft. Note that the tables are for a helm swing between 20 degree limits and are not the lock-to-lock ratings. The response times will vary according to the stiffness of the steering. The drive motor and chain linkage must be mounted in a dry area of the hull.

Table 3.1 Driven sprocket sizes for a 12V system.

Hull length	Up to 11 m	11 to 13 m	Above 13 m
Response time -20 to +20 deg	8 sec	10 sec	12 sec
Shaft revolutions for -20 to +20 deg	Driven Sprocket Size (teeth)		
1	48	60	80
2	25	30	38
3	20	25	25
4	13	15	20
5	13	13	15

Table 3.2. Driven sprocket sizes for a 24V system.

Hull length	Up to 11 m	11 to 13 m	Above 13 m
Response time -20 to +20 deg	8 sec	10 sec	12 sec
Shaft revolutions for -20 to +20 deg	Driven Sprocket Size (teeth)		
1	70	85	105
2	38	38	48
3	25	30	38
4	15	20	25
5	15	15	20

Mount the drive unit so that its shaft is parallel to the driven shaft and the two sprockets are in line. After fitting the chain and adjusting its tension, there should be

12mm of deflection for each metre length of chain. (1/2" for each 3 ft.) Lay the four-core motor/clutch cable back to the Junction Box and terminate it according to Fig 3.11. Note that the CLUTCH NEG terminal is internally connected to the negative power supply terminal.

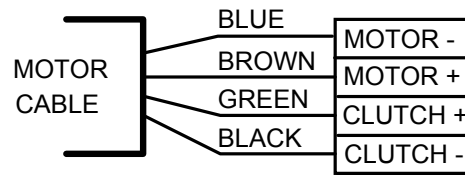

Figure 3.11. Connections to a mechanical steering drive motor.

### 3.6.2. SOLENOID CONTROLLED HYDRAULICS

The motor-drive output of the Junction Box is suitable for direct connection to flow-control solenoids, provided that their operating voltage is the same as the supply voltage to the CM800 system and the solenoid current does not exceed 10A. The connections to the Junction Box are shown in Fig 3.12.

**IMPORTANT:** Before connecting the solenoids, make sure that their wiring does not have connections to ground or any other part of the vessel's wiring.

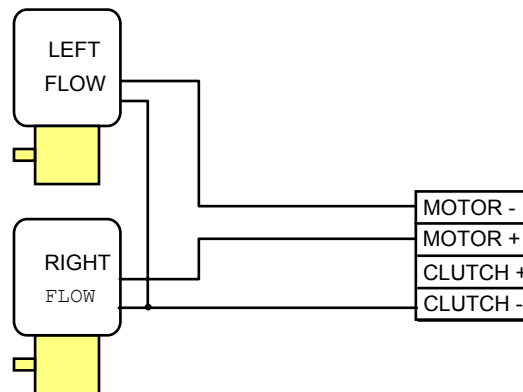

Figure 3.12 Connection to flow-control solenoids.

### 3.6.3 HYDRAULIC SYSTEM WITH REVERSING HYDRAULIC PUMP

Connecting autopilot pumps to hydraulic systems from different manufacturers is not difficult and the following guidelines will be adequate for most installations. If there is a doubt about the correct way to proceed, consult the manufacturer of the steering gear.

The following installation schematics show an OPTIONAL LOCK VALVE. Though this is not essential for the normal operation of the system, it is an additional safeguard in the unlikely event of the failure of the pump. This valve isolates the system into two completely independent sources of steering power and, if required, can be supplied by your Coursemaster agent.

## Two-Line Steering Systems

Two-line systems are by far the most common and are manufactured by many companies world-wide. The best known types include Flexatrol, Hydrive, Marol, Morse, Palm Beach, Seastar, Seipem, Servis, Tenfjord, Teleflex, Vetus, Wills Ridley and Wagner.

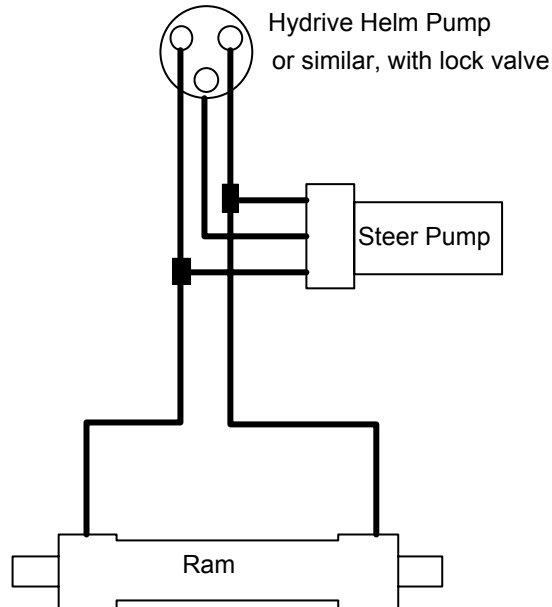

Figure 3.13 Connection to a typical two-line system

Some two-line systems are supplied with a lock valve as part of the helm pump and no additional lock valve needs to be purchased. But the lock valve is an option on, for example, Hydrive and Vetus system. It must be used on Syten outboard systems. If a lock valve is installed, it must be fitted as shown in Fig 3.13.

For information on other systems, including three-line and pressurised systems, please consult the manufacturer's data for those systems.

## Installation Procedure

1. Install the pump according to the hydraulic connection instructions, mounting it close to the tubes connecting the helm pump and cylinder. The pump must be mounted with its rubber foot horizontal.
2. Connect the pump to the system tubing using hose and tubing which is rated for the steering system pressures as specified by the manufacturer. Short lengths of reinforced high-pressure hose should be used to isolate mechanically the Octopus pump from the rigid tubes of the system, as this reduces noise and vibration. The bleed line should not be too narrow as the system may be difficult to purge and may cavitate. Avoid air traps by sloping the pipes upwards from the drive unit.
3. Make sure that there is no foreign matter, such as swarf, in the lines as this may foul the valves and pump. Similarly, thread sealant should be carefully applied well back from the end of the thread.

### **Teflon tape should not be used.**

4. Secure the pipes where necessary to avoid 'pipe whip', since sustained mechanical vibration in the pipes can cause hardening and cracking of the copper.
5. Never install a drive unit without the third (balance) pipe, since the internal pressure build-up could destroy the seals in the pump.
6. Using 20 amp cable, connect the two pump wires to the Motor terminals in the Junction Box (see Figs 3.1 or 3.2), noting that no connection is made to the clutch drive in this type of installation. The polarity of the connection is not important.
7. Fill both the steering system and the pump completely with hydraulic fluid and bleed the hand steering components according to the instructions supplied by the manufacturer.
8. After this bleeding operation, leave the reservoir in the helm open and keep it topped up with fluid. Open the bleeder nipple(s) in the slave cylinder. Run the drive pump in one direction by temporarily removing the drive wires and connecting them directly to the battery. Allow the motor to run for 2 or 3 minutes to purge air through cylinder lines and help to clear the balance line

of air. Under no circumstances allow the oil level to drop in the manual hydraulic helm units - this level must be maintained at all times during the bleeding of the pilot unit.

9. When step 8 has been successful, run the motor in the opposite direction so that both sides of the system are purged. Keep the helm pump reservoir topped up during this operation.
10. When both sides of the autopilot pump system have been bled, repeat the bleed of the drive unit once again, top up the reservoirs, close them and close the bleed nipples. Re-connect the pump wires to the Junction Box. The system is now ready for the setup procedure.

### **Pump Output Adjustment**

Some pumps (eg Octopus) have a flow rate adjustment which can be altered to obtain the correct rudder response time. Check the Specifications chapter of this manual (page 5-2) for the right value for your vessel. To adjust the flow rate, loosen the two screws located on the pump body sufficiently to allow it to be rotated. (If they are loosened too far, oil will be lost.) Rotate the pump body clockwise to decrease the flow or anticlockwise to increase it.

### **Pump Maintenance**

Reversing pumps have a minimum of moving parts and should give hundreds of hours of service without requiring attention. If it fails to run, check first that it is receiving the correct drive voltage from the Junction Box. Next, ensure that the pump shaft is not jammed. (There is normally an access point by which it can be turned with a screwdriver.) If it turns freely and still fails to run, check the motor brush gear.

If the pump runs but does not pump oil, make sure that the system is purged. If that does not succeed, contact your Coursemaster dealer.

### **3.6.4 HYDRAULIC LINEAR DRIVE**

Take care, when handling the ram, that the piston rod is not scratched during installation. It is vital that the cylinder is installed with the correct geometry. The final position of the mounting bracket is ascertained with the piston rod at the middle of its stroke. (Use a ruler to set this position.) With the rudder dead centre and the piston

rod at right angles to the quadrant, mark the position of the bracket and fix it using four stainless steel bolts with locknuts or lock-washers.

The recommended distances from the attachment pin to the centre of the rudder-stock are given in Table 3.3.

Table 3.3 Hydraulic Ram Mounting

Stroke (mm)	Distance to rudder stock (mm).
200	175 - 200
250	200 - 250
300	225 - 300
380	300 - 380

1. Mount the hydraulic pump close to the cylinder on a horizontal surface and in a dry area of the hull. Remove the plastic reservoir cap and replace it with the vented aluminium cap.
2. Ensure that the rudder stops are installed to prevent the cylinder hitting the end of its travel.
3. There are 4 wires on the pump: two for the motor and two for the solenoid bypass valve. When not in PILOT, the bypass valve permits oil to bypass the pump and flow back to the cylinder. Connect the orange and black motor wires to the motor terminals in the Junction Box, using at least 20 amp cable. Connect the two red solenoid wires to the clutch terminals in the Junction Box. (Lighter cable may be used.) Polarity is not important.
4. The cylinder has been bled before shipping. Check the oil level in the pump and, if necessary, top up with automatic transmission fluid.
5. Go to Step 8 in the step-by-step guide at the beginning of the chapter and complete the steps.
6. The hydraulic pump has a flow-rate adjustment which should be set to give the correct rudder response time. Check page 5-2 of this manual for the correct time and adjust if necessary. To adjust, loosen the two screws on

the pump body just enough to allow it to be rotated. Rotate the body clockwise to decrease the flow or anticlockwise to increase it.

7. Bleeding. If it becomes necessary to re-bleed the system, carry out the following:
  - (a) Fill the reservoir with automatic transmission fluid.
  - (b) Locate the two brass bypass screws, one on each side of the solenoid and loosen both 3 - 4 turns.
  - (c) Disconnect the red solenoid wires from the autopilot and apply power directly to the solenoid.
  - (d) Move the piston through its full stroke, one way, then the other. Any air in the system will bubble into the reservoir. Refill the cylinder and repeat until all air has been purged from the system.
  - (e) Re-tighten the bypass screws and reconnect the red solenoid wires.

### **Maintenance**

Check the oil level in the pump at regular intervals. Grease the mounting bracket every 3 months using waterproof grease.

# CHAPTER 4 TROUBLE-SHOOTING

## 4.1 GENERAL

If no error messages are showing, but the performance of the autopilot is unsatisfactory, experience suggests looking initially at four factors. The compass heading should be steady. Small deviations in the heading will not cause performance problems, but random changes in heading of more than a degree or two indicate a defect in the compass performance. If a rate gyro is fitted and selected, two faults indicate a defect in the gyro or its cable: either the heading displayed lags well behind the actual heading or it starts increasing or decreasing steadily when the actual heading is constant. Secondly, if the rudder transducer is not centred correctly or its linkage is faulty, poor steering will result. Finally, free-play or backlash in the steering drive will also cause steering problems.

## 4.2 ERROR MESSAGES

The CM800*i* system is programmed to provide a number of messages on its display when a fault occurs. Some of these are warnings arising out of the way the autopilot is being used. Others mean that a real problem has developed. A full list appears in Sec 2-6. Listed below are those messages for which a more detailed explanation is called for. By using this as an aid, many problems can be fixed simply by the owner. If the assistance of a Coursemaster agent is required, quoting the error message will expedite repairs.

### COMPASS FAULT

If a fluxgate is being used, the heading signals from the fluxgate are above or below the preset limits. The fault must last more than 12 seconds before this alarm becomes active. This prevents a false alarm from being triggered, for example by the fields in a rolling steel vessel. If the system was in PILOT, it remains there with the alarm sounding. The alarm can only be cleared if the fault is corrected.

### **Causes.**

If the error comes up on all headings and cannot be cancelled, the possible causes are a defective connection or cable to the fluxgate, a fault in the compass electronics in the Junction Box, or a defective fluxgate unit. If the message comes up only on some headings, the probable cause is the magnetic environment of the compass - either an excessive horizontal field or vertical field due to local magnetic material. In this case, consult the guidelines in Chap 3.

### **DRIVE OVERLOAD**

The system is in PILOT or one of the power steer modes and the motor drive current has exceeded 20A (CM840) or 30A (CM841) for 1 second. The response to a drive short-circuit is immediate. The system is forced into STANDBY and the message can only be cleared by pressing the STANDBY key after the overcurrent condition is removed.

### **Causes.**

The fault can occur if the mechanical drive or hydraulic pump motor has stalled or jammed. Otherwise, look for a short-circuit in the drive-motor wiring. The fault can also indicate damage to the vessel's steering gear.

### **DRIVE STALLED**

The drive is on, but the helm has not moved over a 2.5 second period. The causes for this can be similar to Drive Overload, but it can also be caused by a linkage failure at the rudder transducer.

### **RUDDER FAULT**

The rudder transducer output is above or below the allowed range. This alarm forces the system into STANDBY and may only be cancelled by pressing the STANDBY key after the condition has been removed.

### **Causes.**

This alarm comes up if the rudder angle exceeds the limits which were set during the System Setup operation. If this has not occurred, the causes are probably in the rudder transducer cable, connections, mechanical linkage or in the transducer itself. Conditions which can cause the alarm to appear are if the transducer is off-centre by more than 10 deg. or the autopilot rudder limit has been set beyond the mechanical limit.

### **4.3 OTHER FAULTS**

The Junction Boxes contain over-voltage protection circuits. If there are large voltage spikes on the power supply, the system may shut down and re-start without an error message appearing. If this happens frequently, consult your dealer about measures to filter the supply.

If the system will not switch on, check the main fuse and second fuse, if fitted. Using a voltmeter, check that the correct voltage is applied to the two power terminals and that the polarity is not reversed. A voltage of about 6V should also appear on the blue Controller lead when the system is off. If these conditions are correct, disconnect all cables except the power and Controller and try to switch on. If the self-test message now appears, the fault is in one of the attachments. If these tests do not reveal the problem, another possibility is that the program store (EPROM) has not been fitted correctly or that a pin is bent or broken. If that is not the problem, a service call is required.

The steering drive transistors are electronically protected, but can be damaged by extreme stress. The common symptom is that the steering will drive one way and not the other. Other types of damage can cause the main fuse to blow when the system is switched from STANDBY to PILOT. In such cases, the Junction Box should be returned to your dealer or to Coursemaster for repair.

### **4.4 FUSES**

The system has two fuses. The main 20A (CM840) or 30A (CM841) fuse protects the complete system, while a 0.8A miniature fuse (See Figs 3.1 and 3.2) protects the control electronics against supply surges.

# CHAPTER 5 SYSTEM SPECIFICATIONS

## AUTOPILOT

	<b>CM840</b>	<b>CM841</b>
Supply Voltage Range (nominal)	12 to 14V dc	12 to 26V dc
Maximum Supply Voltage Range	10 to 16V dc	10 to 32V dc
Supply Current		
Basic system in STANDBY	0.33A	
Add for Controller 2	0.15A	
In Pilot with 20% duty	2.5A	
Compass	Fluxgate in damped suspension	
Typical deviation	2.5 deg rms.	
Rudder Transducer	Potentiometer type	
Rudder position accuracy	1 deg.	
Max rudder angle	+/- 60 deg.	
Clutch drive	1V below the supply voltage at 1A.	
Steering Drive		
Output for 12V supply	10V at rated load	
Output for 24V supply	22V at rated load	
	<b>CM800i</b>	<b>CM841</b>
Max continuous current	16 A	25 A
Max current for 15 sec.	20A	30A
Max current for 1 sec.	40A	50A
Mechanical drive steering motor	Printed rotor with gearbox and electromechanical clutch	
Torque	12V unit: 120kg-cm at 30 rpm/5A. 24V unit: 150kg-cm at 40 rpm/7.5A.	
Hydraulic drive systems	See manufacturers' specs.	
Recommended response times:		
Hull length up to 11 m	8 sec. for -20 to +20 deg swing.	
Hull length 11 to 13 m	10 sec. for -20 to +20 deg swing.	
Hull length above 13 m	12 sec. for -20 to +20 deg swing.	

## NAVIGATION INTERFACE

### NMEA PORTS

Data format and sentences to comply with NMEA0183 V3.00

Serial data format:

Baud Rate	4800
Character format:	start bit, 8 data bits, LSB first MSB (bit 7) = 0, no parity bit, 1 or 2 stop bits
Polarity	
Idle, stop bit, logic '1'	Line A < 0.5V above line B.
Start bit, logic '0'	Line A > 4V above Line B.

### INPUT PORT(S)

Isolated via optocoupler

Input resistance 1000 ohm min.

### OUTPUT PORT

Non-isolated differential output  
Output voltage 18 V p-p (typical)  
Source resistance 1500 ohm max

### AUTOMATIC SENTENCE SELECTION

For navigation inputs, the system looks for groups of sentences in this order:

RMB and RMC  
RMB and GLL  
APB and GLL  
APA and GLL  
BOD and XTE

The search stops on the first complete group. If only one sentence is found from the above combinations, the autopilot operates from the data in that sentence.

For wind vane inputs, the system looks for sentences in this order:

MWV  
VWR

Note that the MWV sentence should contain the symbol R following the wind angle field.

For a digital heading input, the system looks either for the HDG or HDT sentence, depending on which one is selected in the Menu 3 option. Variation and deviation fields are not read.

## OUTPUT DATA

The system outputs heading data in either the IHDG sentence (without deviation or variation data) or as IHDT, using the magnetic variation set within the autopilot. The repetition rate is a minimum of 8 per second.

# CHAPTER 6 MAINTENANCE AND WARRANTY

## 6.1 MAINTENANCE

The only parts of the CM800*i* requiring maintenance are the mechanical components of the steering gear. For mechanical drives, the chain should be oiled every 200 hours of operation and the steel drive sprockets should be lightly smeared with grease to inhibit corrosion.

**CAUTION:** Lubricate the clutch very sparingly, using a very light oil.

The rudder transducer linkage (but not the transducer itself) should be oiled each 200 hours of operation.

For hydraulic systems, follow the maintenance instructions supplied with the system.

Great care has been taken in the selection and sealing of materials in the system to minimise the risk of corrosion. If, however, the controller or any other component is accidentally immersed in water, it should be drained immediately and returned promptly to your Coursemaster agent for cleaning and rectification.

## **6.2 INSTALLATION OF NEW SOFTWARE**

It is recommended that software upgrades be installed by a Coursemaster agent, but if this is not possible, the following procedure should be followed carefully by the owner. The memory package containing the software for the main circuit board in the Junction Box has a label beginning CM840V..... Open the Junction Box and, referring to Fig 3.1 or 3.2 in the manual, locate the Program Store. Slip a slim bladed screwdriver through the access hole at the rear of the base, inserting it between the package and its socket. With a gentle twisting movement of the screwdriver, lever the package up so that it remains parallel to the surface of the board until free of the socket.

Check the new package to ensure that all pins are straight and at right angles to the package. If they tend to splay outwards, bend them inwards by rocking the package on a hard smooth surface. Insert the package in the socket, making certain that the small notch at the end of the package lines up with the small notch on the socket.

## **6.3 WARRANTY**

Coursemaster Autopilots Pty. Ltd. is committed to the principles of product support and customer satisfaction. It warrants its autopilots and accessories against defective materials and workmanship for a period of twelve months (six months in the case of commercial applications) from the date of installation, provided that the total period does not exceed eighteen months from the date of shipment from Coursemaster Autopilots Pty Ltd.

Parts exhibiting defective material or workmanship will be repaired or replaced at our option without charge to the first owner for the duration of the warranty, provided that they are returned to our factory at the owner's cost and risk. This warranty does not extend to components showing corrosion or other water damage which has resulted from water exposure as a result of incorrect installation or inadequate protection.

Coursemaster Autopilots Pty. Ltd. shall not be liable for any expenses or for any direct or consequential damage caused by defects, failure or malfunction of their autopilots or accessories whether a claim is based on a warranty contract, tort or otherwise.